



⋮

⋮

⋮

⋮



“ ”







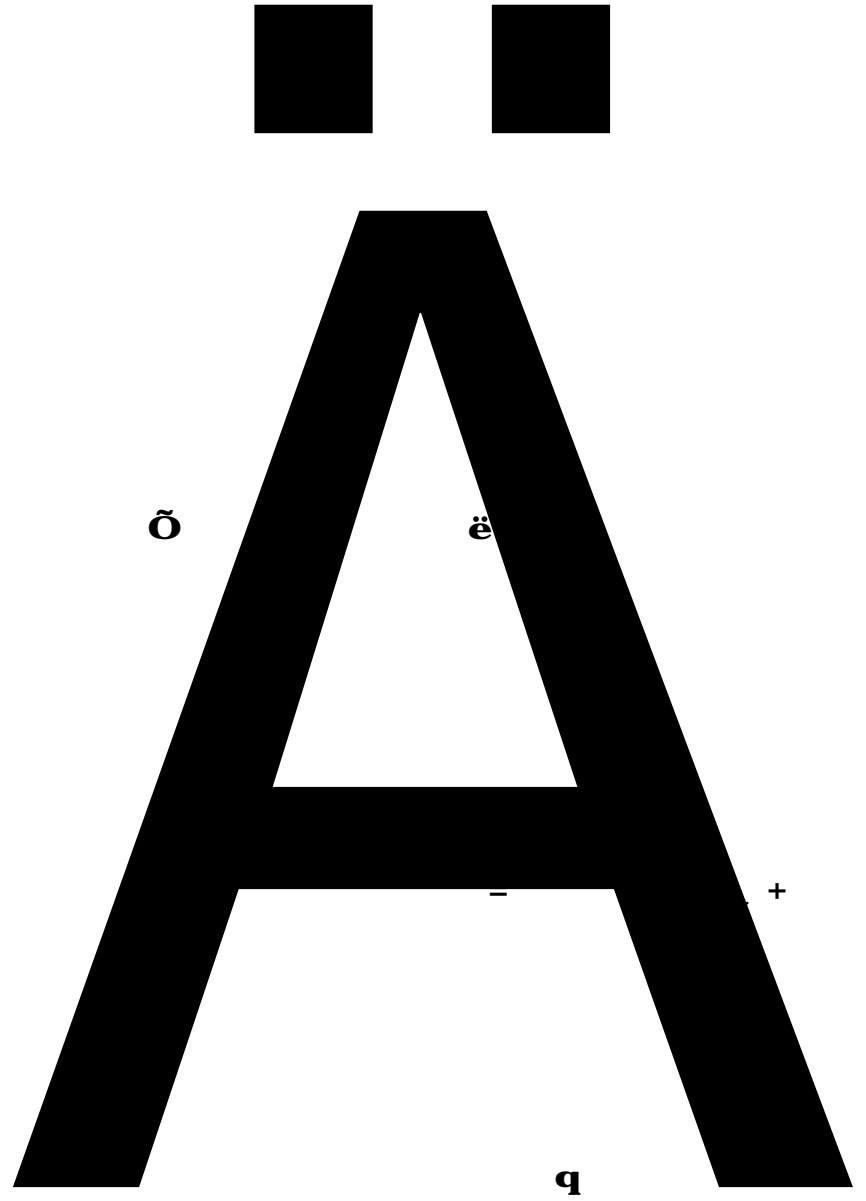











--	--	--	--

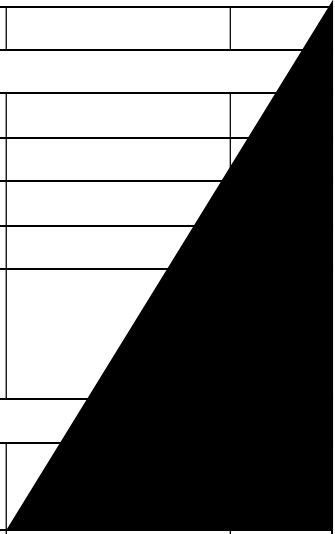



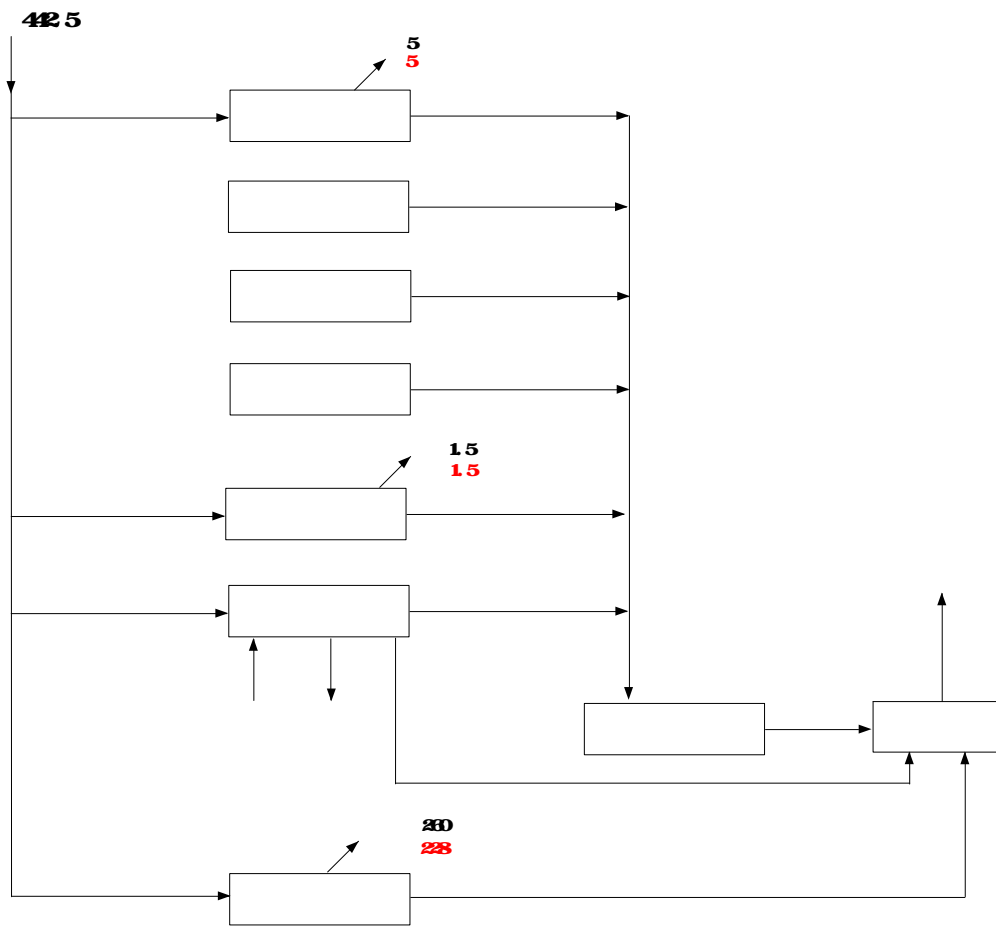

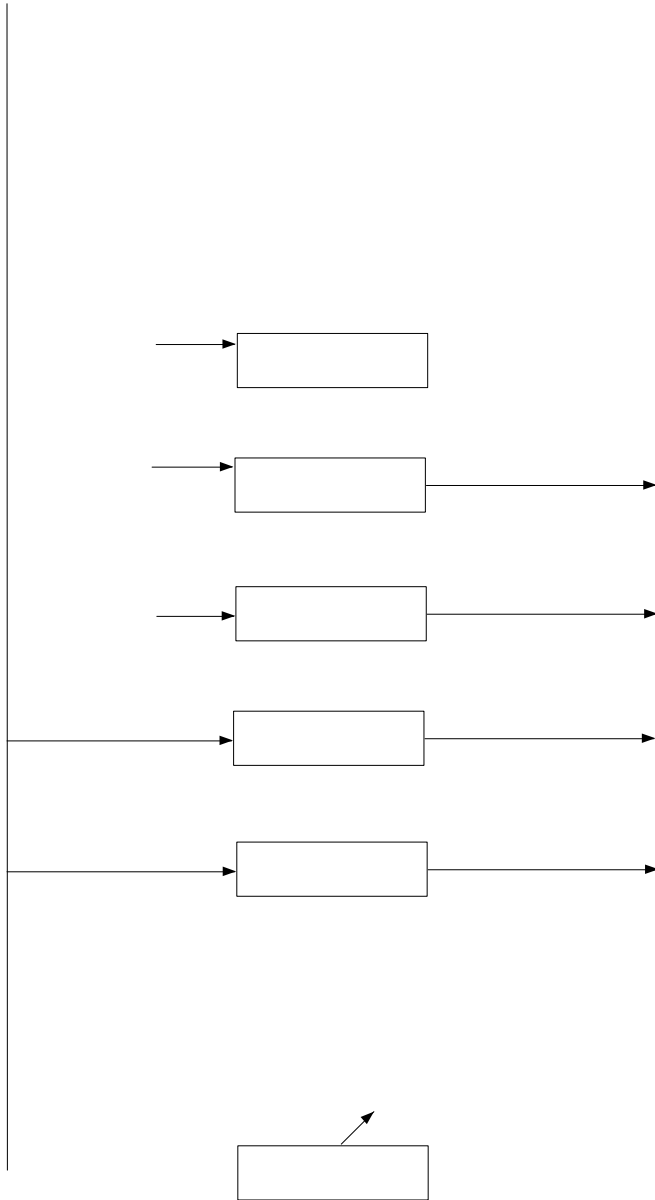







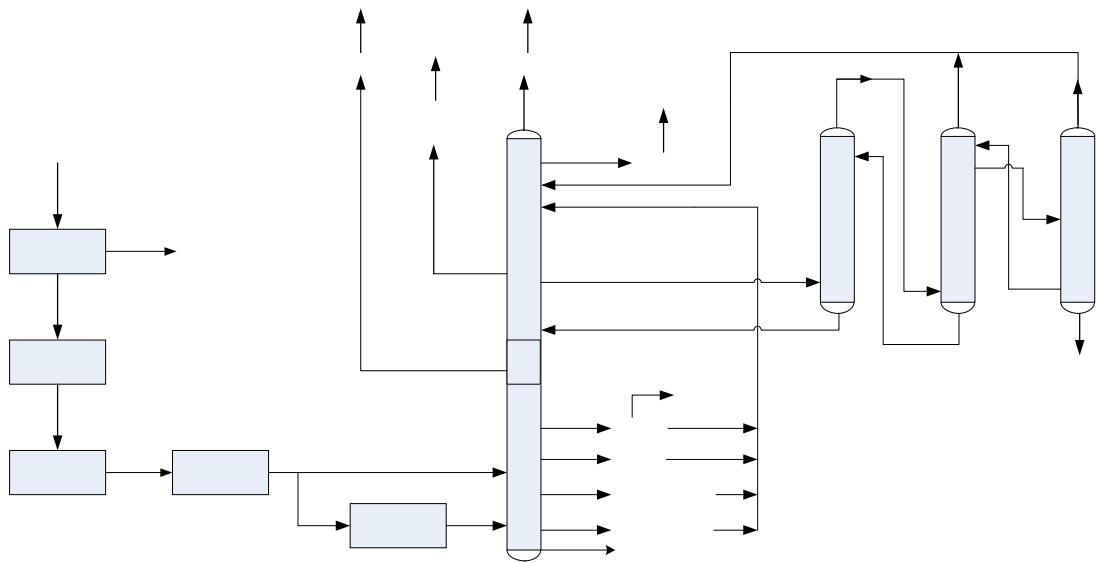



**352**

**q**

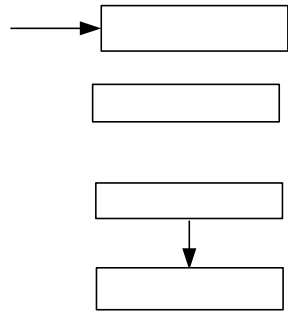



**T ° 3 T**

**W CE 3**

**f**

						<b>0</b>	
						<b>+88/5a</b>	

**353**

















**356**

**71 m<sup>3</sup>/h**

**7 m<sup>3</sup>/h**



**411**

**71 m<sup>3</sup>h**

**7 m<sup>3</sup>h**

Å Ä



**413**

							$+88/5a$	
							+	
							$+36/2a$	
							$+24/5a$	

**414**

**415**

**416**

> |

**A**

; Ā



**512**

**513**

**514**

**515**

**516**

**517**

**2024 15 2024 10 15**







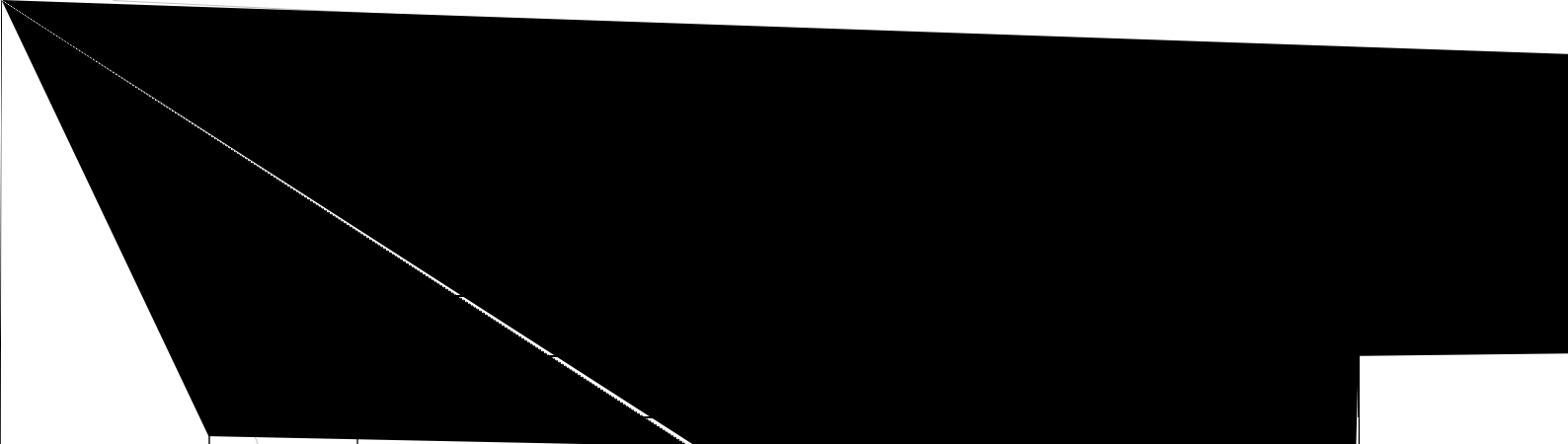

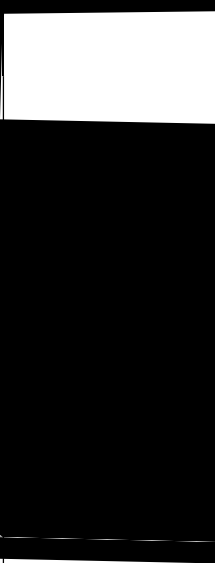



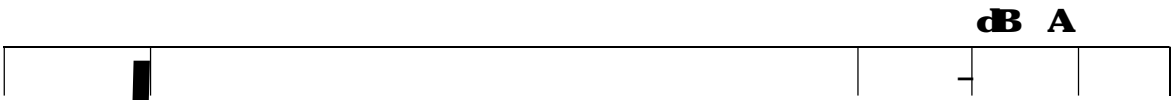
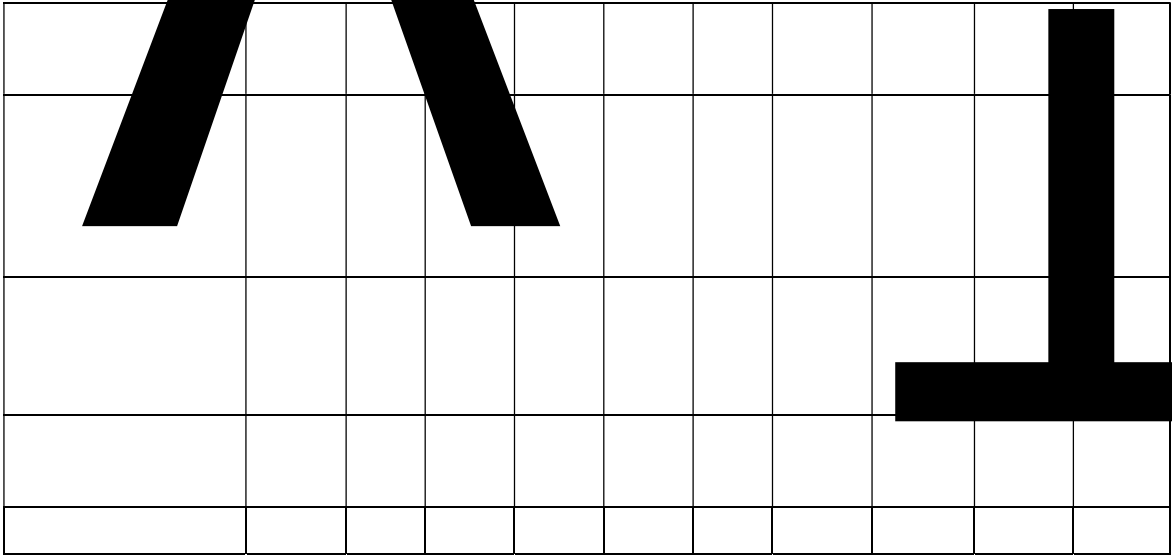

\_\_\_\_\_



--	--	--	--

t9™!@1` fg` Bt9™ ò h` 0









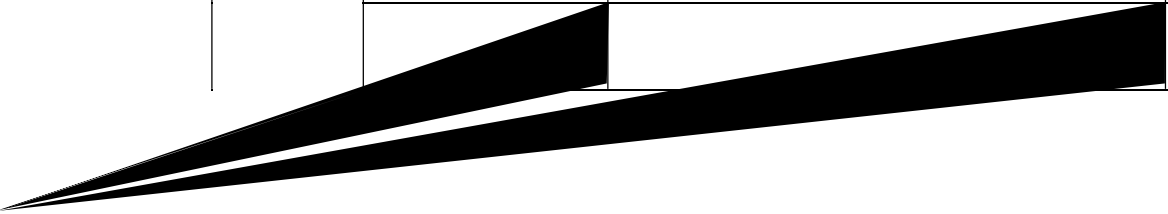

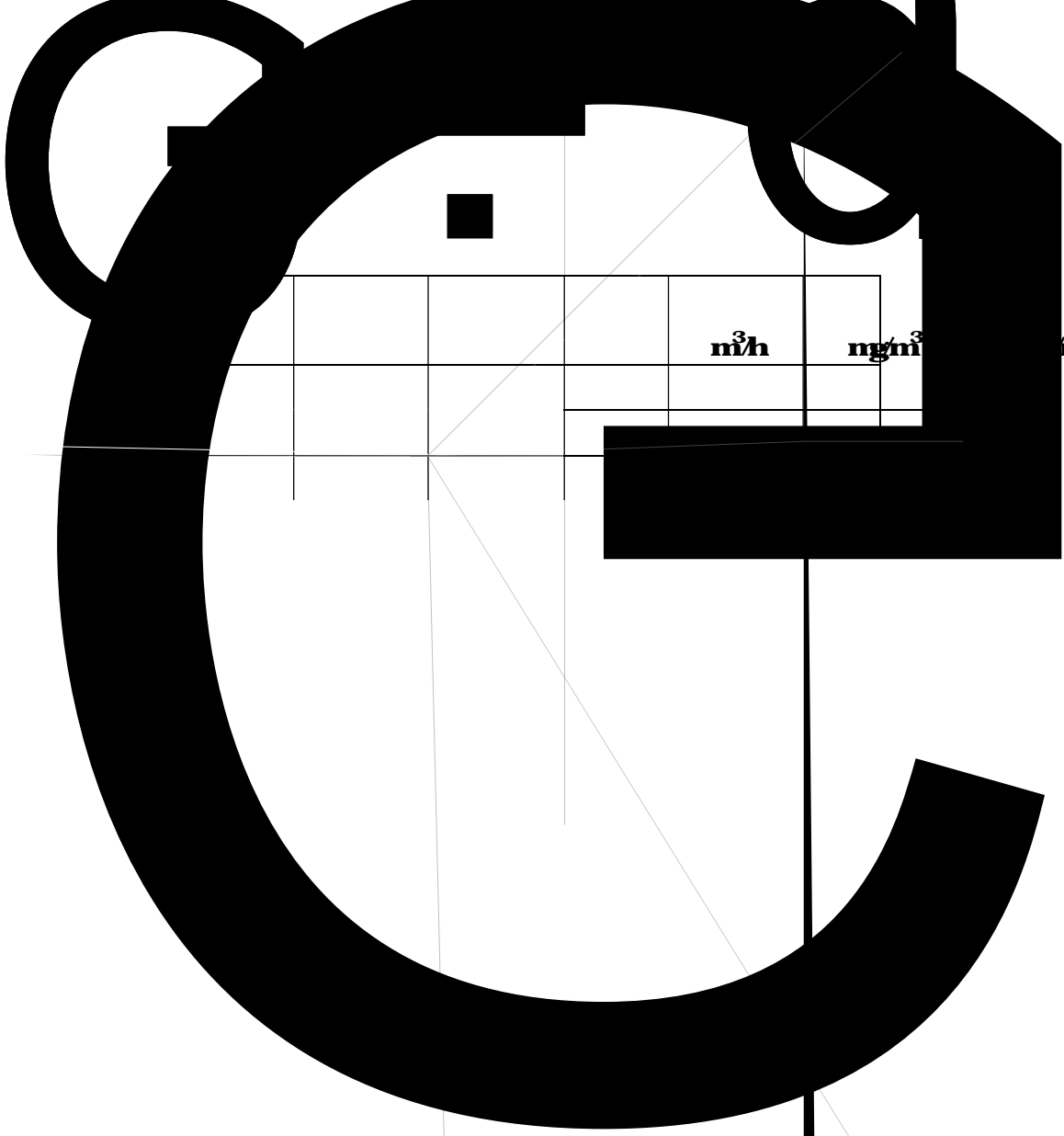



$m^3/h$

$ngm^3$

$m^3$

lgh



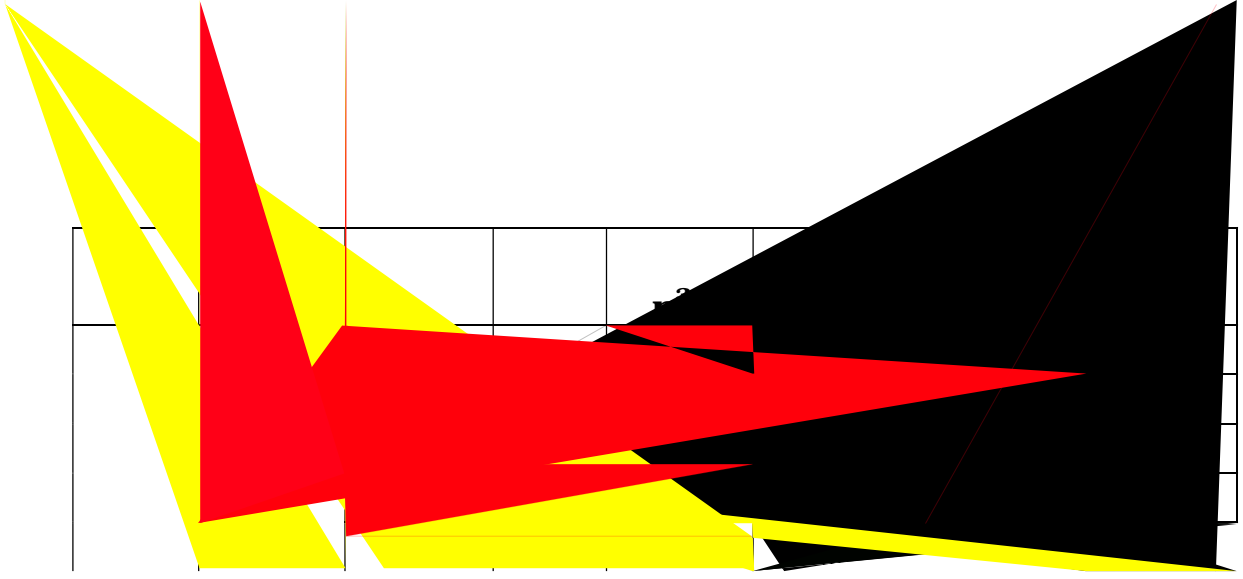



A

Ā

	<b>1</b>	<b>2</b>	<b>3</b>	<b>4</b>		
P J w	AB	H 28\$ P J				
			<b>29</b>			
		p b	hpô Q W	hv©™\$ U™™€	U™™€	H 28\$ P P

**dB(A)**







**1 2**



**:ta**

**1021**







Ã

“ ”